

Car Recycling

Europe

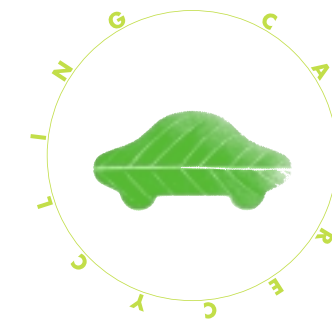

 **TOYOTA**



Contents

**Introduction:
Making People-friendly and
Environmentally-friendly Cars** 4

**Current Status of Recycling:
What happens to End-of-Life Vehicles** 5

**Recycling Activities all along the
Life Cycle of Cars** 6

**The Recycling Working Group
Recycling activities** 6

**Recycling as a Key Issue in Product Design
- the Development Stage** 8

**Avoid Waste through Recycling
- the Production Stage** 10

**The Essential Support of Dealers
- the Use Stage** 12

**Striving for Sustainable End-of-Life
Processes - the Disposal Stage** 14

This brochure can be found in English at:
<http://www.toyota-europe.com>
and in the other languages on the national Toyota sites

Main contact:
Toyota Motor Marketing Europe
Environmental Affairs Office
Avenue du Bourget 60
B - 1140 Brussels
Tel. 0032 2 745 2486
Fax: 0032 2 745 2067
E-mail: eaco@toyota-europe.com

Making People-Friendly and Environmentally-Friendly Cars

In order to ensure that automobiles will continue to be a sustainable mode of transport in the 21st century, Toyota considers it important to proactively take action to reduce their environmental impacts all along their life cycle. One of the aspects Toyota is focusing on is the recycling stage.

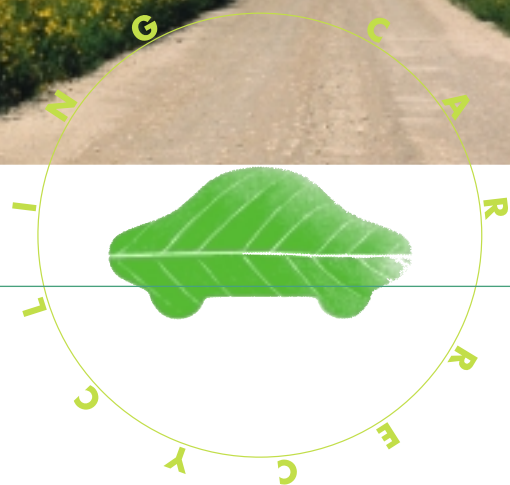
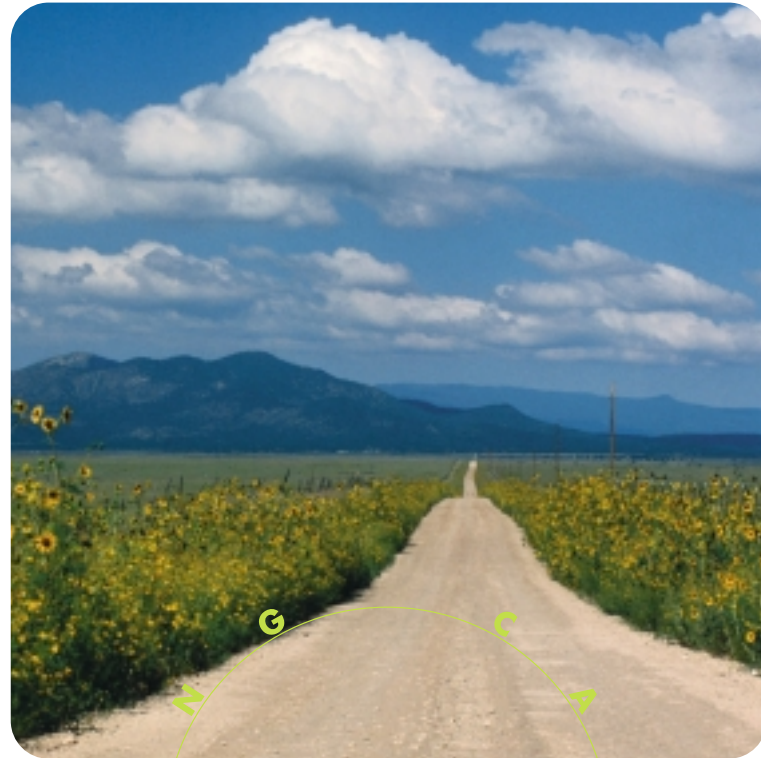

Recycling as One Approach

Automobile recycling is a positive contribution to the reduction of many environmental impacts. In fact efficient utilisation of resources by reusing discarded materials or using them as energy sources lessens the impact on the environment due to the depletion of natural resources and the potential pollution related to disposal to landfill.

At Toyota, we are thinking about recycling opportunities at every stage of life cycle of vehicles, i.e., development, production, use, and final disposal.



What Happens to End-of-Life Vehicles?

Automobiles manufactured by automakers and used by consumers until the end of their useful life are referred to as end-of-life vehicles. At present, approximately 75% to 80% of end-of-life vehicles in terms of weight, mostly metallic fractions, both ferrous and non ferrous, is being recycled. However, the remaining 20% to 25% in weight, consisting mainly of heterogeneous mix of materials such as resins, rubber, glass, textile, etc., is still being discarded. From end-of-life vehicles, dismantling companies first remove the oil, engine, transmission, tire, battery, catalytic converter, and other parts, which are

commonly recycled or reused. Shredding companies then sort out the ferrous and non-ferrous metals and resin from the remaining vehicle bodies. While the ferrous and non-ferrous metals are recycled, the shredder residue is being disposed of as waste in landfills.

In order to most effectively utilize the earth's resources and reduce the volume of disposable waste, automobile recycling activities must include efforts to further reduce the volume of this waste and promote its reuse and recycling to ultimately achieve zero waste.

Disposal route for end-of-life vehicles

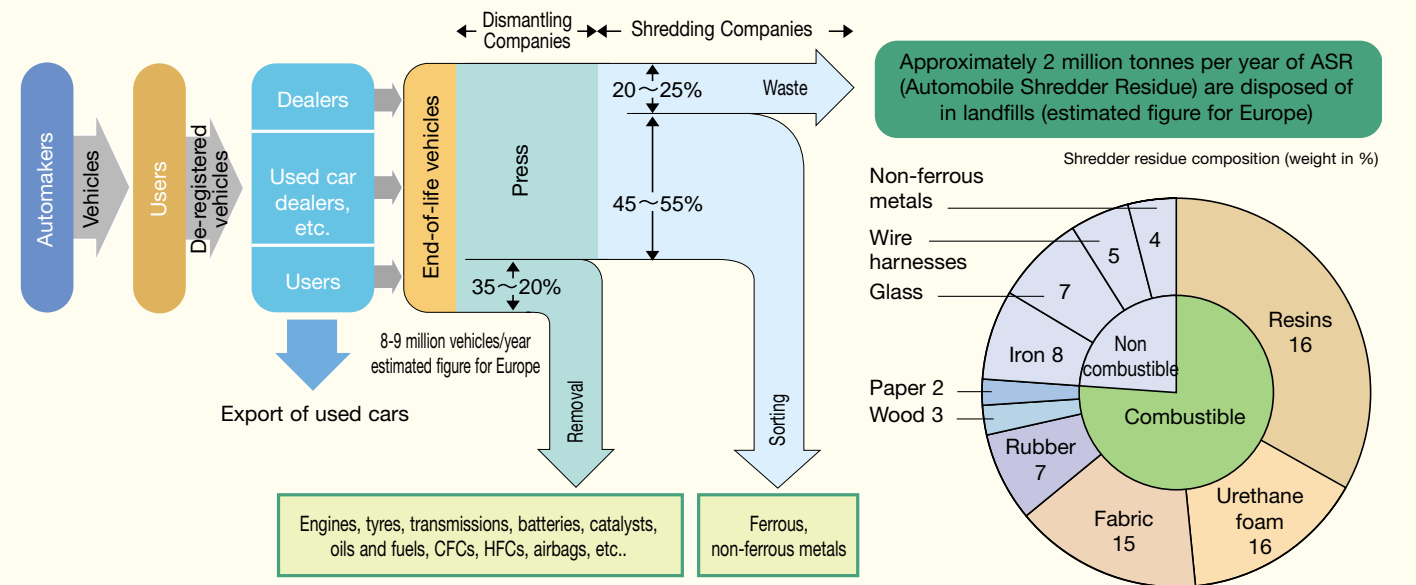

In October 2000, the European Union adopted the End-of-Life Vehicles (ELV) directive (2000/53/EC) which seeks to prevent and limit waste and improve the re-use, recycling and recovery of ELVs and their components. The directive also promotes eco-design, the usage of recycled materials and the improvement of the environmental performance of all of the economic operators (e.g. shredders, dismantlers) involved in the vehicle life-cycle.

The ELV directive's targets for re-use, recovery and disposal include:

- A minimum of 85% in weight of ELVs should be recovered as of 2006, including a maximum of 5% energy recovery, and, from 2015, a minimum of 95% in weight, including a maximum of 10% of energy recovery.

- Banning the use of hazardous substances, such as lead, mercury, cadmium and hexavalent chromium for new vehicles as from July 2003, excluding parts where it is essential for use.

Toyota endorses the directive's requirements, and is actively working with its European National Marketing and Sales Companies to meet the challenges the directive raised. Given the vital role they play, Toyota is also working in close co-operation with recycling and shredding companies to develop better and more efficient solutions for dealing with end-of-life vehicles.

A requirement of the directive is to make information about the above topics accessible to perspective buyers of vehicles.

Recycling Activities all along the Life Cycle of Cars

Recycling should be addressed as a key issue during the entire life cycle of an automobile, from its conception to the end-of-life stage. Accordingly, Toyota is involved in activities to reduce waste as much as possible and recycle whatever can be reused at the development, production, use, and disposal stages. In order to more effectively use non-renewable resources, early in the development stage, Design for Recycling techniques are also put in place.

The Recycling Working Group

To control and monitor environmental policy goals, and ensure full legal compliance and integration of environmental performance throughout the business process, Toyota has established in Europe an Environmental Committee and Working Groups, one of which is dedicated to "Recycling".

The main objectives of this working group are in line with the requirements of the ELV directive, and in the attainment of the recyclability and recoverability targets for vehicles sold in the European market.

The working group members are conducting research into efficient dismantling technologies for end-of-life vehicles, promoting the utilisation of shredder residue and setting up a strategy for boosting the usage of recycled materials for some specific car components.

Furthermore the Recycling Working Group gives its support to the main Toyota Recycling Committee, based in Japan, on Design for Recycling.

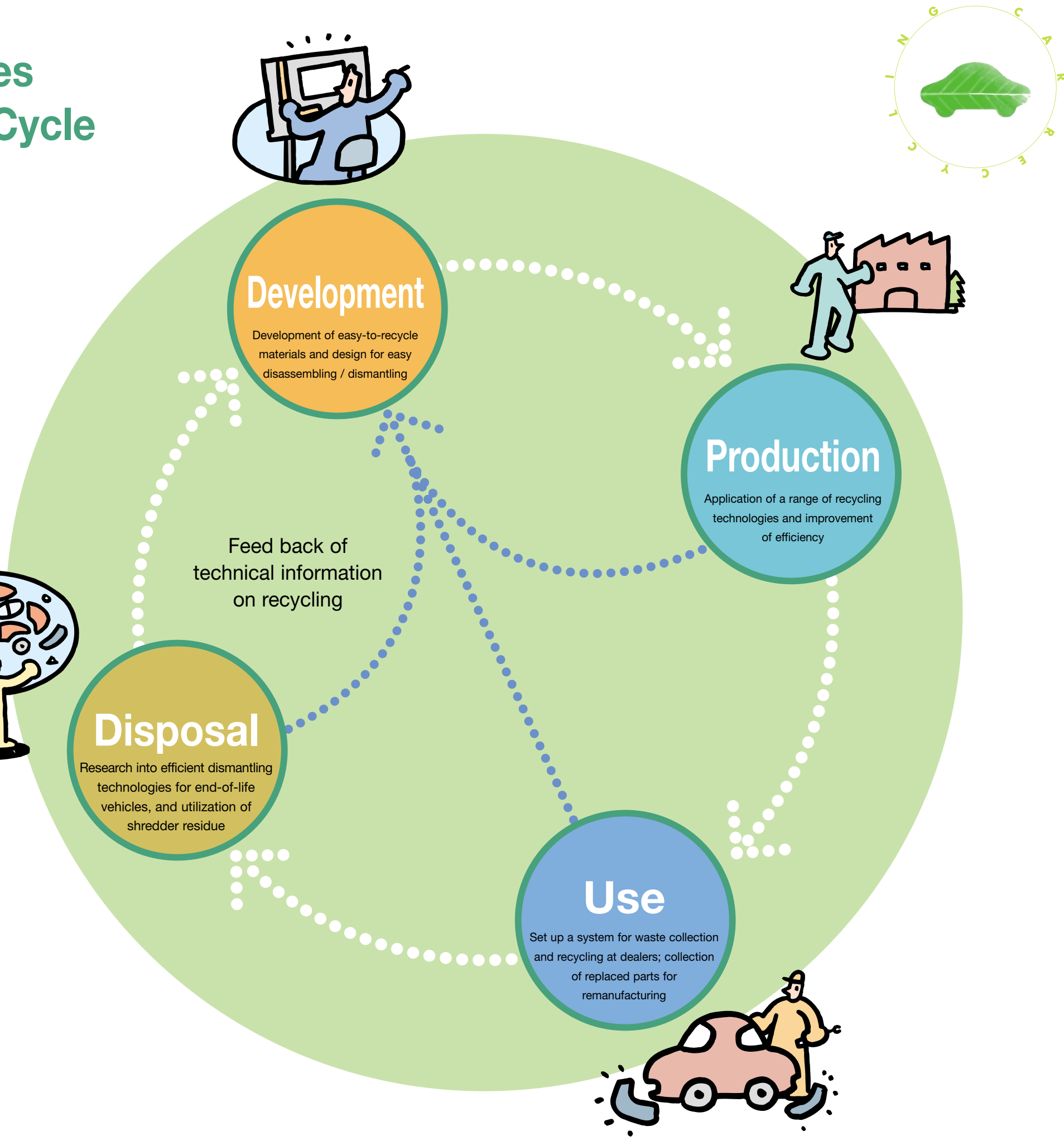

Recycling Activities

- Recycling at the Development Stage**
 - Recoverability Prior Assessment System
 - Design that takes Recycling into Consideration
 - Design with Due Care of Environmental Impact
- Recycling at the Production Stage**
 - Resin Recycling Technology
 - Rubber Recycling Technology
 - Application of a Range of Recycled Materials
- Recycling at the Use Stage**
 - Recycling of Waste by Dealers
 - Remanufactured Parts
- Recycling at the Disposal Stage**
 - A Practical Tool for Dismantling
 - Pioneer Recycling Plant Operational in Japan
 - Effective Utilisation of Shredder Residue
 - Enhancing Research through the Automobile Recycling Technical Center
 - Building the Prius Battery Recycling System

Recycling as a Key Issue in Product Design

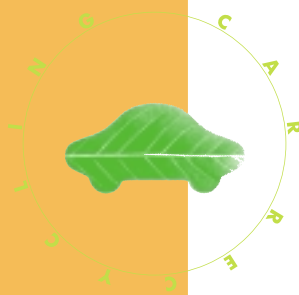

In the development stage Toyota has been developing easy-to-recycle materials and taking removability into consideration. This process takes benefit from feedback of information from all along the recycling chain.

Recoverability Prior Assessment System

In the area of recycling, Toyota formulated design guidelines for vehicle recycling based on the technologies developed for recycling plastic parts and on the results of evaluation and research on vehicle dismantlability. These guidelines are used for the prior assessment of recoverability during the development stage of each vehicle series. They describe detailed design standards related to the selection and removability of several hundred plastic parts, as well as to substances of environmental concern. By continuously enhancing these guidelines and by promoting improvements in the Prior Assessment System, Toyota is trying to ensure that vehicle design takes recoverability into consideration. At the beginning of 2001, the Recoverability Prior Assessment System was applied to 20 different vehicle models.

crystallization theory, in 1991 Toyota developed and commercialized Toyota Super Olefin Polymer (TSOP), a thermoplastic resin which has better recoverability than the conventional reinforced composite polypropylene (PP). This TSOP is already being used in a wide range of interior and exterior parts in new models, such as the front and rear bumper of the new Corolla. The molecular design of TSOP resin underwent many refinements and Toyota has been using this improved material since September 1999.



TSOP bumpers in new Corolla

Design that Takes Recycling into Consideration

1 Innovations in materials

Resin materials to be used in automobiles must possess high rigidity and high impact resistance as well as superior recyclability — that is, they must not deteriorate easily when recycled. Taking advantage of a molecular design technology based on a new

2 Innovations in vehicle structure

In order to improve the recoverability of dismantled parts, Toyota is using the same type of thermoplastic resin for instrument panels, air-conditioning ducts, insulation pads, and sealing materials. Moreover, these parts are installed using friction welding rather than screws or metal clips, thereby eliminating the need for dismantling operations during recycling. This new design has been adapted in the Hiace (light commercial vehicle).

In addition to these assembly and structure reevaluations, Toyota is working toward producing designs that take recoverability into consideration through reduction and integration of parts and joints.

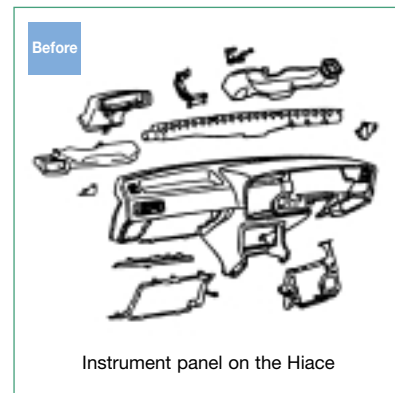

Instrument panel on the Hiace

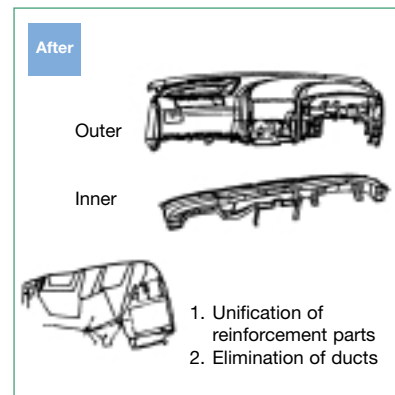

Outer
Inner

1. Unification of reinforcement parts
2. Elimination of ducts

3 Innovations in the sorting process

As early as 1981, Toyota launched a material ID marking system to help identify materials used in resin parts. Currently, a marking system that conforms to international standards is used for resin and rubber parts weighing more than 100 grams.



Example of ID marking

Design with Due Care of Environmental Impact

There is more and more pressure to decrease the volume and increase the quality of the shredder residue generated from end-of-life vehicles. Therefore, Toyota has been considering for some time now, at the design stage, the reduction of the amount of lead, which has been gaining attention as a substance of environmental concern in automobile shredder residue. In new Corolla, produced in the UK, Toyota has succeeded in developing parts, which are now lead free. For example, the wire harness traditionally required lead for heat resistance but Toyota has developed an alternative heat resistant material for the wire harness, which contains no lead. Other examples include the radiator, heater core, fuel hose, and the fuel tank. Big efforts are also being made to significantly improve the treatment of airbags containing gas-generating materials.

1 Milestone to phase out lead

Toyota's voluntary target was to reduce the amount of lead used in new models, excluding that in batteries, to 1/2 of the (1996) industry average by 2000; it is now further proceeding to phase it out.

2 Development of airbags with consideration to disposal

The gas generator used in airbags has generally been sodium azide, a toxic substance that is converted in a harmless material when the airbag explodes. Nevertheless this gas makes undetonated airbags disposal a potential concern for the environment. Toyota, working in close cooperation with parts manufacturers, has developed - and put in place - airbags that employ a substitute compound, phasing out the use of sodium azide.

To enable easy airbag deployment, Toyota has developed and adopted standard connectors, which enable simultaneous processing of airbags in the driver's seat as well as in the front passenger's seat; these are

available on all models for the Japanese market and on some models for the European one. Possibilities for standards harmonisation within the automobile industry globally are currently under investigation.

Use of material that takes recycling into consideration in the LS430

- TSOP (Toyota Super Olefin Polymer)
- TPU (Thermo Plastic Urethane)
- TPO (Thermo Plastic Olefin)
- RSPP (Recycled Soundproofing Products)
- Recycled PP (Polypropylene)
- Kenaf (natural fiber)

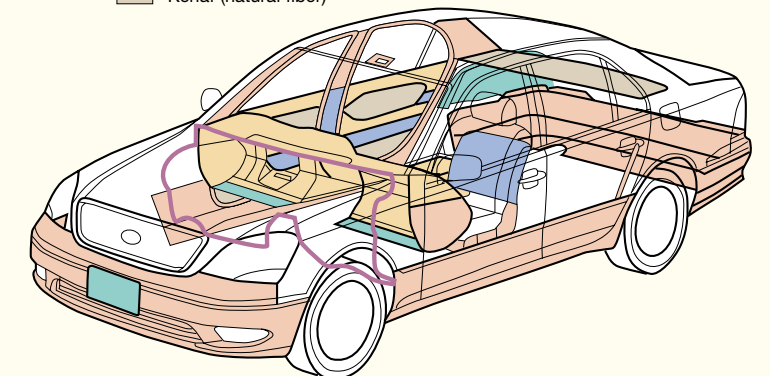

Example of parts from which lead has already been eliminated

- Battery cable terminals
- Copper radiators
- Copper heater cores
- Undercoating
- High pressure hoses for power steering
- Side-protection moulding
- Wire harnesses
- Seat belt G sensors
- Fuel hoses

Example of parts for which lead elimination is underway

- Fuel tanks
- Glass ceramic print
- Meter needle balancers
- Constant velocity joint grease
- Wheel balancers
- Electrodeposited paint

Example of parts for which lead elimination technology is under development

- Other engine components
- Other body parts
- Printed circuit boards etc.

Avoid Waste through Recycling

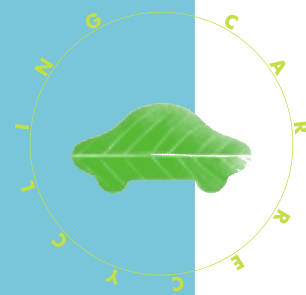

Toyota is strongly committed to developing technologies for effectively utilising resin and rubber, which are difficult to reuse or recycle due to difficulties in separation of composite materials and to high quality standards requested. The recycling technologies that have been developed are first applied to the remnant materials generated in production processes; commonly remnants from the manufacturing of plastic parts are recycled internally, for example in the case of bumpers. Toyota has extended the application of these recycling technologies to the parts collected at dealers and from end-of-life vehicles.



Bumper production at the Toyota plant in Valenciennes (France)

Resin Recycling Technology

Floor carpets used in automobiles consist of composite materials and thus, are extremely difficult to recycle.

Toyota has developed a technology for recycling the remnant materials generated in the floor carpet production process into a resin material, which is utilized as the backing material for floor carpets and as the raw material for moulded parts.

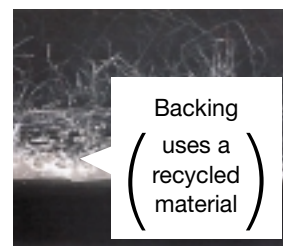

Sectional view of a floor carpet

Rubber Recycling Technology

Waste rubber generated in the production processes can also be recycled into regenerated rubber for automobile parts.

Together with Toyota Gosei Co., Ltd., Toyota developed the world's first waste rubber recycling technology in 1997. Full-scale application of this technology started in 1998. At present, approximately 200 tons per year of waste rubber is being recycled for Toyota vehicle production in Japan as weather stripping to water-proof vehicle doors and trunks.

● New waste rubber recycling technology

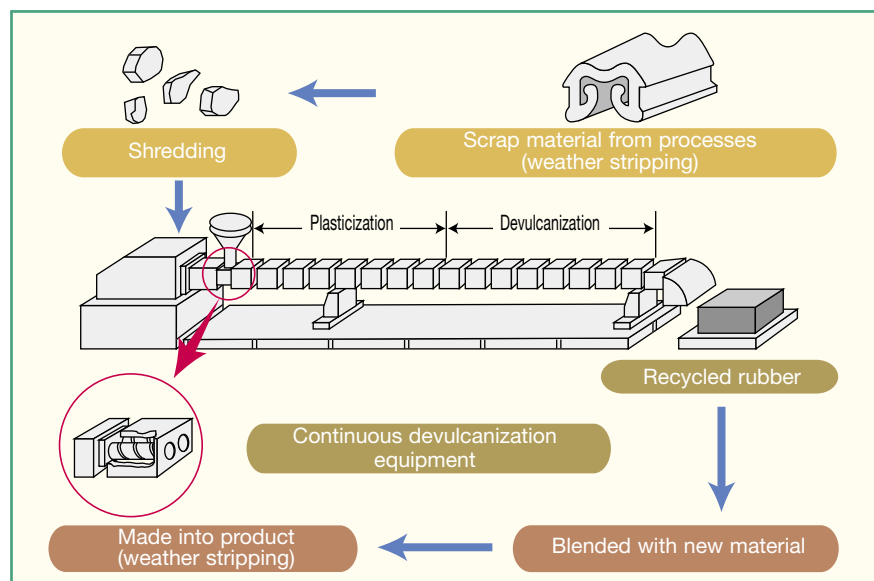

Applications of Various Recycled Material

Technologies for material recycling developed by Toyota

Type	Original Item	Recycled Part	
Thermoplastic resin	TSOP (Toyota Super Olefin Polymer) bumper	Bumper	Fuel tank protector
		Luggage trim	Fuel pump protector
		Seat backboard	Seat under-cover
		Lamp cover	Back door trim cover
		Engine under-cover	Luggage compartment trim
		Bumper step	Deckside trim
	Interior trim, garnish	Timing belt cover	Fan shroud
Thermosetting resin	FRP parts (Fiber Reinforced Plastic)	Sunroof housing	Cylinder head cover
Resin composite material	Carpet	Carpet backing	Carpet reinforcement parts
	Seat fabric	Floor silencer	
	Instrument panel covering	Dash silencer	
	Molded roof lining	Luggage trim	
Rubber	Weather stripping	Hose protector	Weather stripping
Automobile Shredder Residue (ASR)	Urethane foam & fiber	RSPP (Recycled Sound-Proofing Products)	
	Copper wiring	Reinforcing materials for aluminium casting	
	Glass	Reinforcing materials for tiles	
Other	PET bottles	Sound absorbing materials	

● Example of manufacturing of engine covers from recycled PET bottles, in Japan

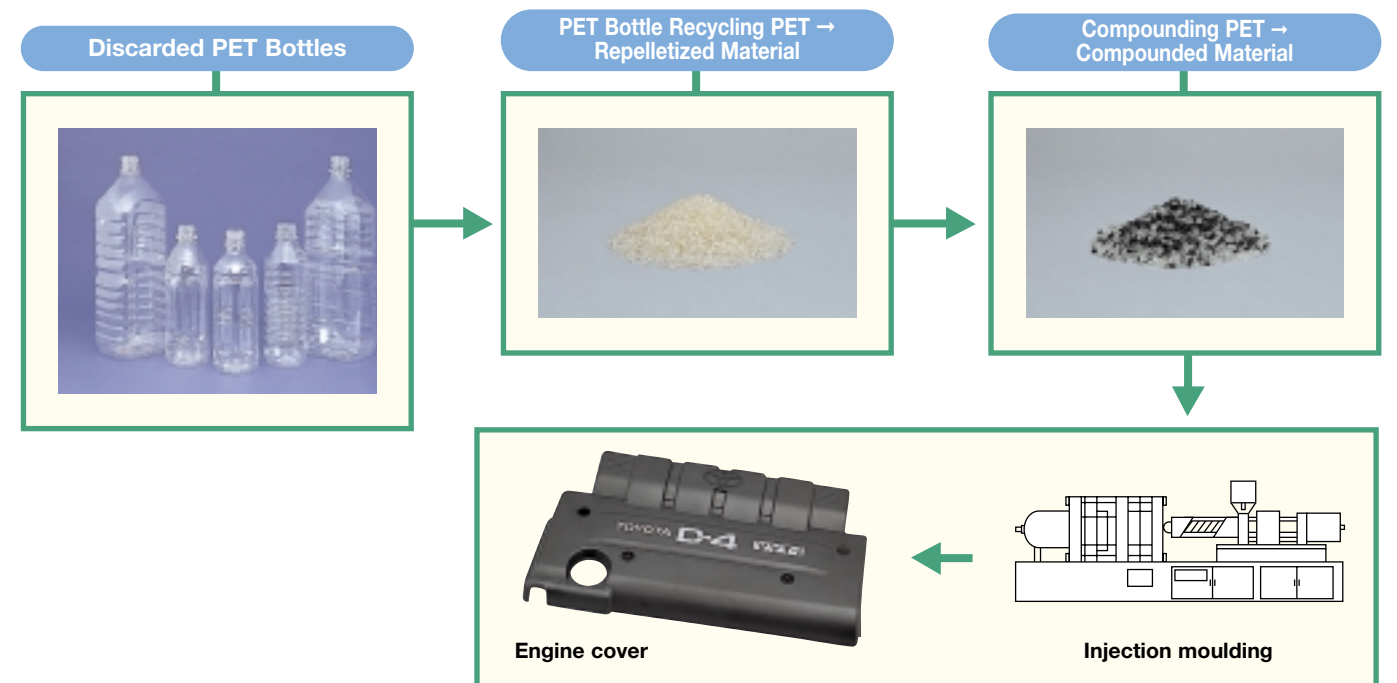

The Essential Support of Dealers

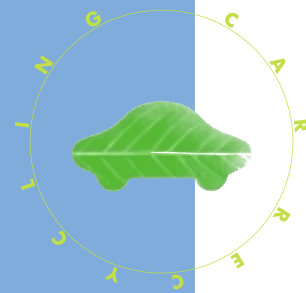

Different kinds of waste are produced during car maintenance at the workshops, some of which is recyclable. Toyota requested the support of dealers for enhancing the recycling of consumables and spare parts through an increased efficiency of collection and the setting up of contacts with recycling companies. Furthermore Toyota is promoting sales of remanufactured parts.

Recycling of Waste by Dealers

In early 2001, Toyota published the Environmental Guidelines for National Marketing and Sales Companies (NMSCs).

The Environmental Guidelines set out specific requirements that relate to recycling activities at dealer service areas. All dealers must implement a waste management system, taking into account all local regulations and compliance conditions. Through this,

Toyota in Europe has been actively participating in promoting the development of comprehensive dealer waste management systems. In this scope, some mandatory categories for collection, such as batteries, tires, waste oil, oil filters, brake fluid, paint and solvents, have been identified. In Germany, over 230,000 oil filters and 25,000 car batteries were collected in 2001 and sent for recovery. While in France, some 50,000 oil filters and almost 3,000 batteries were collected and processed.



Independent technician fitting genuine exhaust



Independent body technician in body shop

In several European markets, NMSCs are already operating nation-wide systems for the management of dealers waste through agreements with selected partners. These partners are responsible for the management of dealer service area waste, from collection to sorting and treatment.

For example, in the UK Toyota and Lexus dealers work together with approved waste management companies such as Cleanaway. They ensure that all hazardous and general waste materials removed from the dealerships are disposed of properly and recycled or recovered, whenever feasible and economically viable.

A bumper recycling project is also in place in Germany. Toyota dealers remove from old bumpers metal, parts and stripes; bumpers are then collected and transferred, via regional hubs or depots, to a grinding facility for recycling.

Remanufactured Parts

In terms of product development, Toyota is actively pursuing an environmentally friendly policy, through the expansion of its genuine remanufactured parts range. These products reuse many components, thereby eliminating the requirement for new raw materials and saving the energy needed to turn these materials into the finished product. It is expected that over the next three years, Toyota will introduce between 10 and 15 new remanufactured product ranges, all of which will be available from all Toyota dealers in Europe.

In 2002 Toyota has launched, to all European markets, remanufactured air conditioning compressors and power steering racks and are currently working on remanufactured engines, short-blocks and cylinder heads, with the launch of these planned for beginning of 2003.

In addition, Toyota in Europe has coordinated the development and implementation of a more efficient parts return system, with used parts being returned through the main European parts distribution center, instead of direct from dealers to supplier. In the long term this will ensure that more cores are returned correctly and the system managed more professionally.

The following parts, tested and approved in accordance with Toyota standards, are available:

- remanufactured starter
- remanufactured alternator
- remanufactured clutch kit
- remanufactured automatic transmission
- remanufactured air conditioning compressors
- remanufactured power steering racks



Example of remanufactured parts now available on the European market

Striving for Sustainable End-of-Life Processes

Current recycling rates vary from country to country due to differences in the recycled/recovered materials markets, labour costs, landfill costs, and the levels of quality and professionalism in collection and dismantling, at treatment facilities and in technology. This explains the necessity for matching the early stages of Design for Recycling with current economical sustainable practices. Toyota is both cooperating with other auto manufacturers and growing in-house expertise in that direction.

A Practical Tool for Dismantling

Dismantling the end-of-life vehicle is the first step of the treatment process, and the accuracy and quali-

ty of this process determines the possibility of re-utilisation and recycling of parts and components. As part of the European end-of-life, auto manufacturers must provide dismantling information for each type

of new vehicle put on the market. In order to meet this requirement, Toyota joined a Consortium of more than 20 manufacturers, which prepares dismantling information in an electronic format - the International Dismantling Information System (IDIS). This information is regularly updated and distributed to the authorised dismantling network in Europe. More information on the IDIS system can be found on the web site at <http://www.idis2.com>.



Examples of parts being recycled from end-of-life vehicles

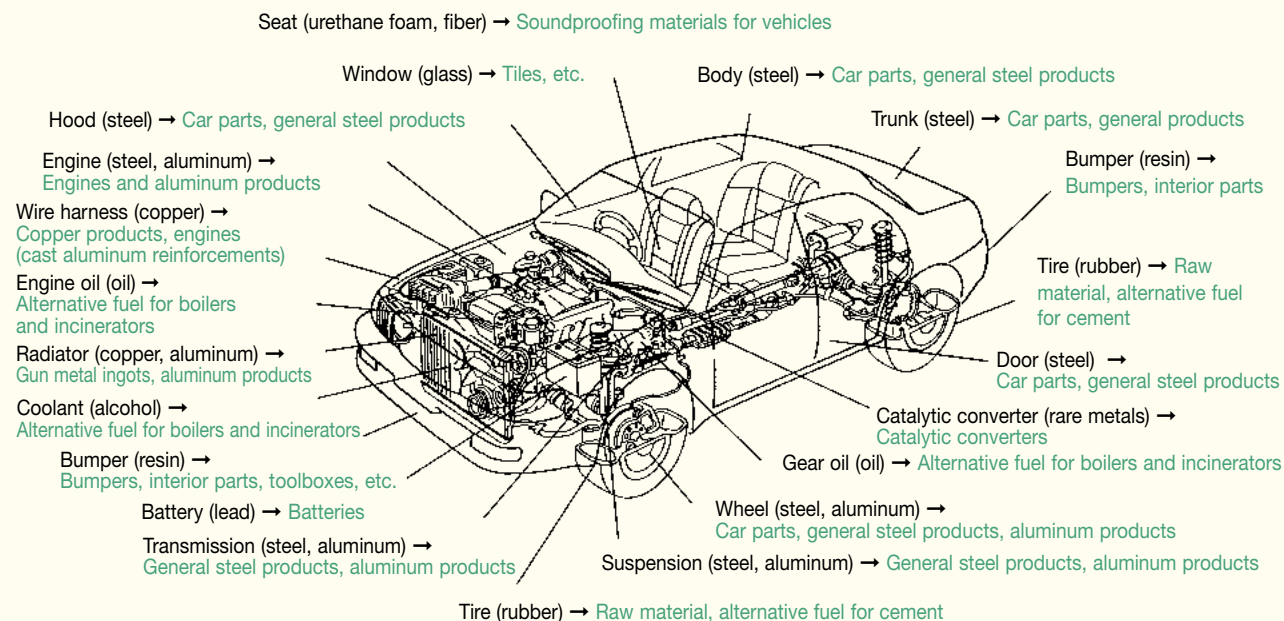

Pioneer Recycling Plant Operational in Japan

During the dismantling process, engines, tires and other vital parts are first removed from end-of-life vehicles. The body is then crushed by a shredder and ferrous and non-ferrous metals are recovered. The remaining shredder residue, containing pieces of resin, rubber, glass and other items, was thought to be virtually impossible to recycle and disposed of as waste in landfills. In 1993,

Toyota, together with Toyota Metal Co., Ltd., began to develop technology for effective utilization of shredder residue and then constructed the world's first mass-production recycling plant, with a capacity of recycling about 15,000 end-of-life vehicles per month, which went into operation in August 1998. This centre provides research results for Toyota design divisions and provides information worldwide to help dismantling, shredding and recycling companies improve recycling methods.



The Recycling Plant (Toyota Metal Co., Ltd.)

Effective Utilization of Shredder Residue

Toyota independently developed technologies for dry separation, sorting and recycling. By means of these technologies, the minute pieces of rubber, glass etc. in the shredder residue can be recycled into excellent, new material.

1 Development of RSPP

Urethane foam and fabric, the major constituents of shredder residue, are sorted out and recycled into RSPP (Recycled Sound Proofing Products), a soundproofing material now being reused in several vehicle parts. Compared to conventional products, this new soundproofing material has ample air pockets that maintain a good balance between its sound insulating and sound absorbing characteristics for exceptional soundproofing performance.

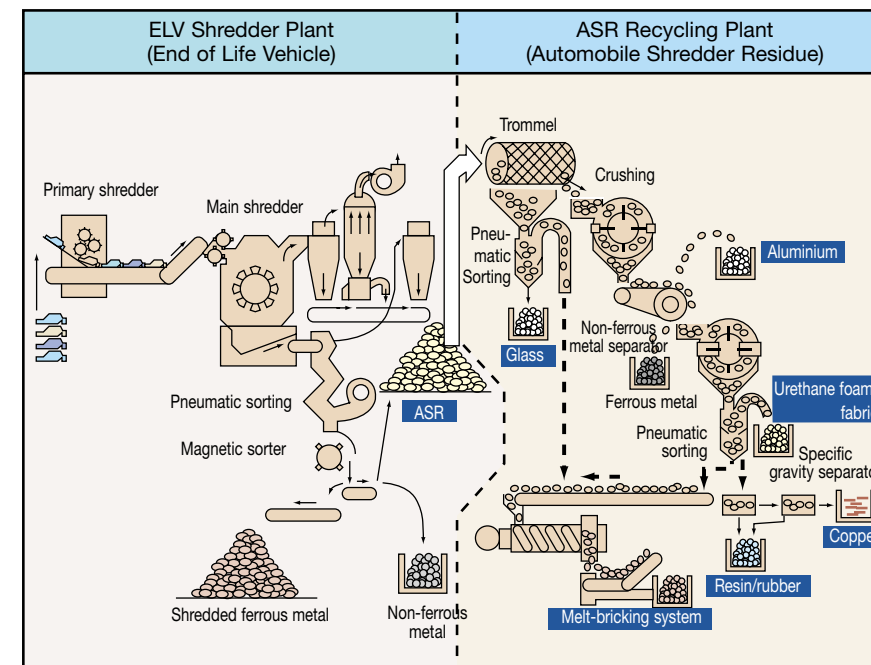
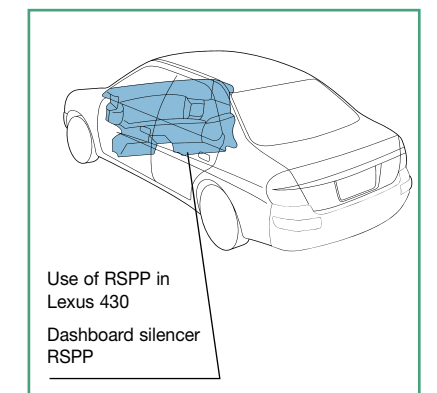
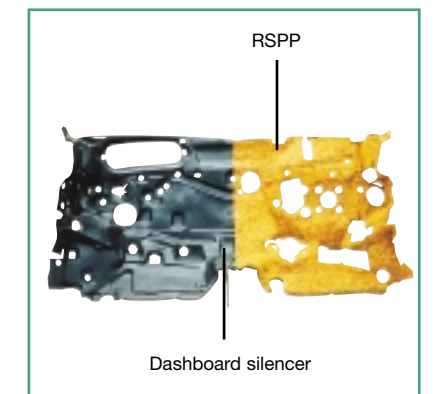

2 Recycling of wire harnesses

Toyota independently developed a high-precision sorter to separate wire harnesses. After the plastic shields and connectors are removed, the remaining copper (of purity 97% or above) is recycled. In Japan, the separated copper is currently being used at foundries as reinforcing material in aluminium castings.



A high-precision sorter is used to separate wire harnesses. The plastic shields and connectors are removed, and the remaining copper is recycled.



Aluminium engine cylinder heads using the sorted copper as reinforcing material.

3 Glass as raw material for the ceramic industry

Utilizing the high-quality characteristics of automotive glass, powdered glass from shredder residue is recycled into tiles with remarkable density and strength, and also used as materials for landscaping pavement.

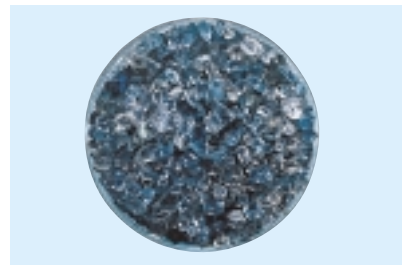

Sorted glass

4 Alternative fuels

The sorted resins form the bulk of shredder residue in terms of weight, and uniform pieces size. They have a high heating value on par with that of coal. This gives them the potential to be used as substitutes for coal and kerosene. Toyota, with Sanei Industry Co., Ltd., set out to research the possibility of using sorted resins as an alternative fuel, and succeeded in commercialization. This fuel has been in actual use in Japan since April 1999.



Shredder residue

5 Melt-bricking technology greatly reduces landfill waste volume

From 1996, controls were imposed on ASR (Automobile Shredder Residue) landfills in Japan, and the regulations on permissible leaching levels of harmful metals were made more rigorous. In addition, in 1999, the European landfill directive laid down strict acceptance criteria for hazardous and non-hazardous waste in landfill. To conform to these new regulations, Toyota developed a melt-bricking technology that uses a high-speed screw to knead and heat the ASR, reducing both its volume (1/5 of previous levels) and the amount of lead leaching. As a first step, this enabled Toyota to meet the new regulations for controlled landfill sites in Japan.

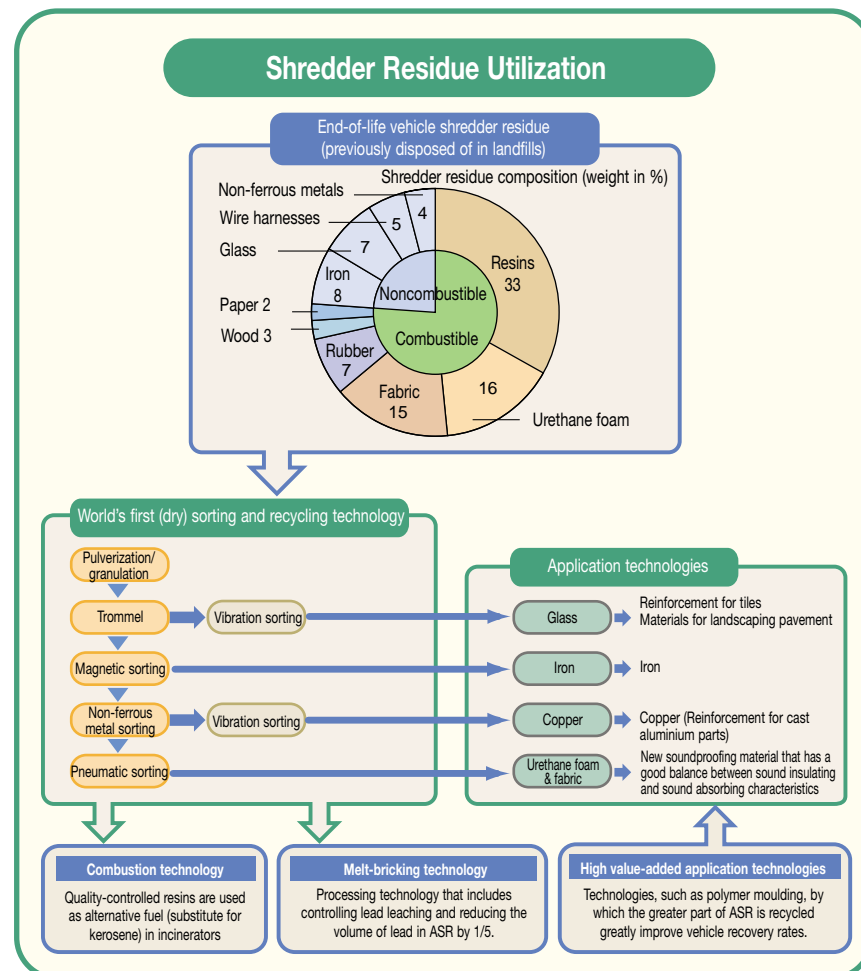

Enhancing Research through the Automobile Recycling Technical Center

The year 2000 witnessed some major developments with regard to recycling. A new law was enacted in Japan, the goal of which was to promote a recycling-based society while in Europe a directive was issued to ensure the collection of end-of-life vehicles, their treatment under environmentally sound conditions and their reuse and recovery. At that time a Toyota recycling plant was already in operation but Toyota decided to further advance recycling technologies from his accumulated base and established, inside Toyota Metal Co., Ltd., the Automobile Recycle Technical Center.



Study of removability of exterior components



Study of removability of fluids



Study of removability of chassis-related parts

The Technical Center began operation in April 2001, to accelerate the pace of research related to recycling, the Technical Center will work on subjects such as "easy-to-dismantle vehicle structures" and "appropriate and effective dismantling technolo-

gies," which affect all divisions. Research results will be fed back to design divisions within the company, and dismantling information will be disclosed to dismantling companies, thereby helping to promote recycling.



Automobile Recycle Technical Center (Handa City, Aichi Prefecture), Japan

Positioning of the Automobile Recycle Technical Center

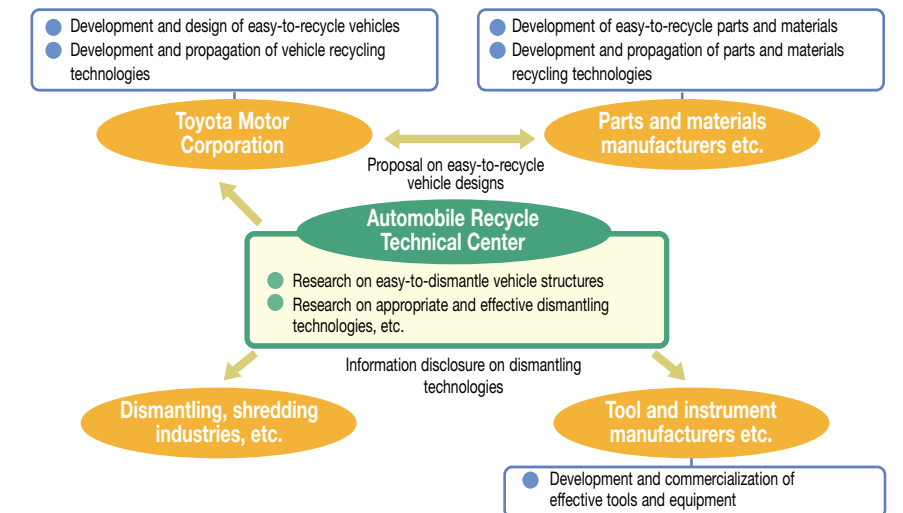

Cooperative relationship with Toyota Motor Corporation

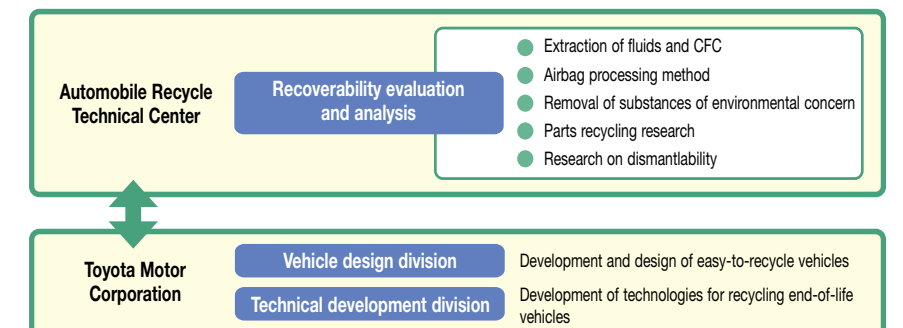

Building the Prius Battery Recycling System

Final disposal of batteries is considered to be a key issue in the life cycle of electric vehicles. To make Prius, Toyota's mass-produced hybrid vehicle, the ecological car market leader in terms of battery disposal, the issue has successfully been solved by Toyota.

About Prius Batteries

The Toyota Prius Hybrid System battery is a high voltage (~280V) NiMH (Nickel Metal Hydride) battery, weighing approximately 40 kg. The battery contains 38 modules, each sealed

and comprising six cells. To minimise the risk of mishandling, National Marketing and Sales Companies (NMSCs) ensure direct collection by specialised companies.

In all countries where Prius is sold, roadside assistance and emergency services are informed on how to handle Prius batteries in the case of a vehicle breakdown or accident.

Battery recycling in practice

Even before the European debut of Prius, Toyota established in Europe a dedicated NiMH battery recycling network. All those involved in the system - from customers, local authorities, emergency services,

dealers, to independent workshops and garages - have been informed that Toyota Prius dealers are the central collection points for batteries. After collection, Prius batteries are transferred to a certified Toyota recycling company. Current certified companies include: SNAM and Citron in France; Accurec in Germany; Batrec in Switzerland; Saft in Sweden. Other treatment companies can be approved by TMC upon request. A "Prius HV Battery Dismantling Manual" was developed and distributed to Prius Dealers, focusing on precautions to be observed when dismantling a damaged vehicle.

● Prius battery recycling system

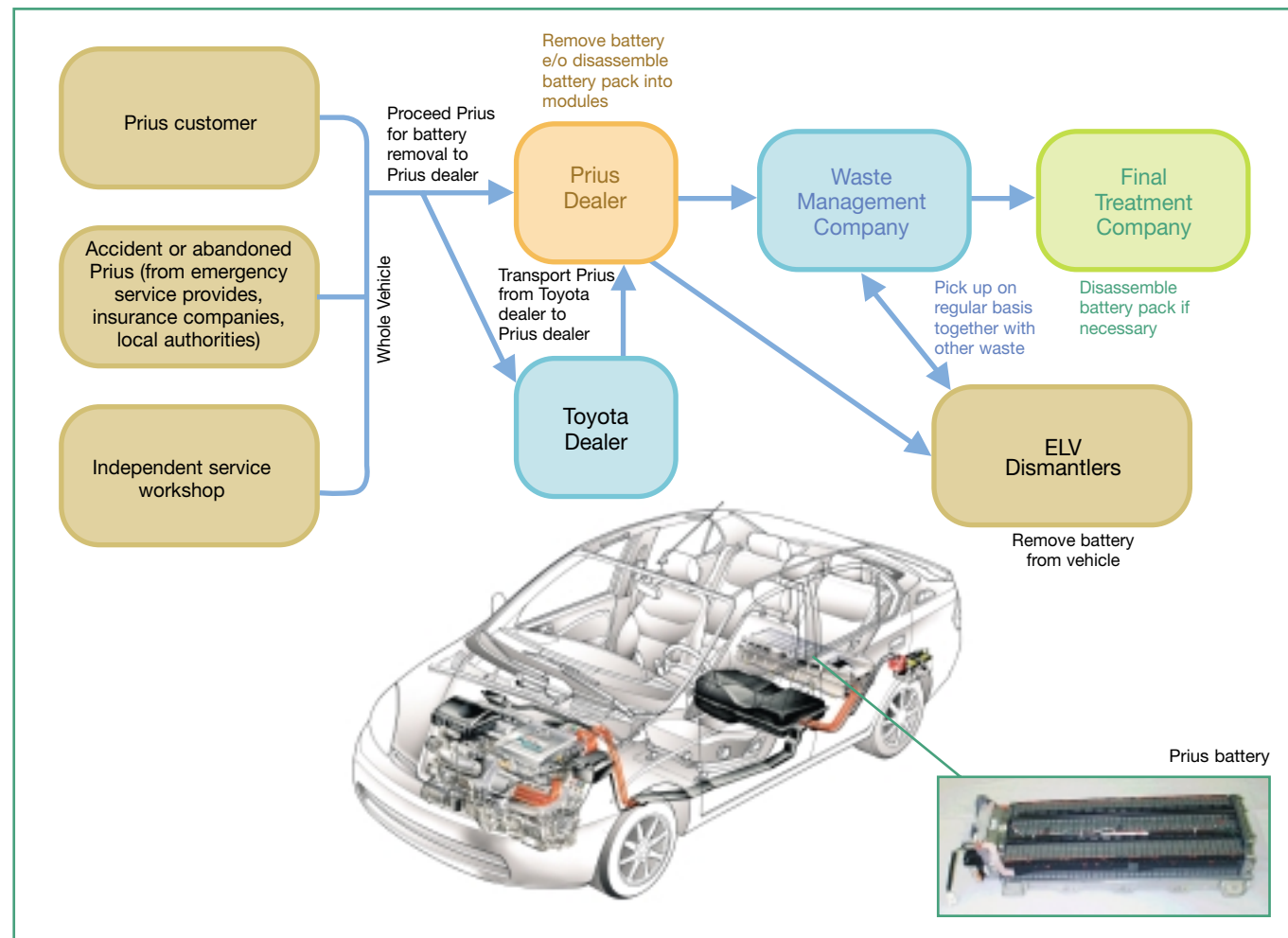

New Toyota Earth Charter

Implementing Consolidated Environmental Management

Action Guidelines

1. Always be concerned about the environment

Challenge achieving zero emissions at all stages, i.e., production, utilization, and disposal.

- Develop and provide products with top-level environmental performance
- Pursuit of production activities that do not generate waste
- Implement thorough preventive measures
- Promote businesses that contribute toward environmental improvement

2. Business partners are partners in creating a better environment

Cooperating with associated companies.

3. As a member of society

Actively participate in social actions.

- Participate in creation of cyclic society
- Support environmental government policies
- Contribute also to non-profit activities

4. Toward better understanding

Actively disclose information and promote environmental awareness

Basic Policy

I. Contribution toward a prosperous 21st century society

In order to contribute toward a prosperous 21st century society, aim for growth that is in harmony with the environment, and challenge achievement of zero emissions throughout all areas of business activities.

II. Pursuit of environmental technologies

Pursue all possible environmental technologies, developing and establishing new technologies to enable the environment and economy to coexist harmoniously.

III. Voluntary actions

Develop a voluntary improvement plan, not only based on thorough preventive measures and compliance to laws, but that addresses environmental issues on the global, national, and regional scales, and promotes continuous implementation.

IV. Working in cooperation with society

Build close and cooperative relationships with a wide spectrum of individuals and organizations involved in environmental preservation including governments, local municipalities, as well as with related companies and industries.



This pamphlet was made from 100% recycled paper.
No chlorine was used for bleaching and no surface
processing or special coating was applied.

Published by: TOYOTA MOTOR MARKETING EUROPE
Environmental Affairs Co-ordination Office
Tel: 0032 2 745 24 86
Fax: 0032 2 745 20 67
E-mail: eaco@toyota-europe.com
Published: October 2002 (based on the Japanese version
issued November 2001)